

FLUSH MOUNT - SolarHot hot water collectors

Minimum Design pull out per mounting foot as a function of design wind pressure ⁽¹⁾

	20 psf	30 psf	40 psf	50 psf
SolarHot				
4' x 80" (26.67 sq. ft.)	134	201	268	335
4' x 8' (32 sq. ft.)	160	240	320	400
4' x 10' (40 sq. ft.)	200	300	400	500

Roof truss lumber	Specific Gravity	Design pull-out ⁽⁵⁾ (lbs/1" penetration)	Calculated available pull out force per SolarHot flush mounting foot ^{(2) (3) (4)}
Douglas Fir - Larch	0.50	305	1220
Douglas Fir - Suth	0.46	269	1076
Engelmann Spruce, Lodgepole Pine (MSR 1650 f & higher)	0.46	269	1076
Hem - Fir	0.43	243	972
Hem Fir (North)	0.46	269	1076
Southern Pine	0.55	352	1408
Spruce, Pine, Fir	0.42	235	940
Spruce, Pine, Fir (E of 2 million psi and higher grades of MSR and MEL)	0.50	305	1220



- ⁽¹⁾ Each SolarHot hot water collector to be mounted with four (4) mounting feet;
Flush Mounted collectors **DO NOT** share a common set of (2) mounting feet between panels
- ⁽²⁾ Based on 2-3/8" lag screws per mounting foot embedded 2" in a rafter or other structural roof member
- ⁽³⁾ Pull-out values incorporate a 1.6 safety factor and a 1.6 load duration factor as recommended by the American Wood Council
- ⁽⁴⁾ See Uniform Building Code for required edge distance
- ⁽⁵⁾ Value for one (1) 3/8" diameter lag screw with one inch (1") of penetration

Conclusion:

Based on the above numbers the worst case scenario (4'x 10' collector mounted in Spruce-Pine-Fir with a specific gravity of 0.0.42) provides an available pull out value 88% greater than the wind requirements for a 50 psf wind location.

TILT MOUNT - SolarHot hot water collectors

Minimum Design pull out per mounting foot as a function of design wind pressure ⁽¹⁾

	20 psf	30 psf	35 psf
SolarHot			
4' x 80" (26.67 sq. ft.)	267	400.5	467
4' x 8' (32 sq. ft.)	320	480	560
4' x 10' (40 sq. ft.)	400	600	700

Roof truss lumber	Specific Gravity	Design pull-out ⁽⁵⁾ (lbs/1" penetration)	Calculated available pull out force per SolarHot flush mounting foot ^{(2) (3) (4)}
Douglas Fir - Larch	0.50	305	1220
Douglas Fir - Suth	0.46	269	1076
Engelmann Spruce, Lodgepole Pine (MSR 1650 f & higher)	0.46	269	1076
Hem - Fir	0.43	243	972
Hem Fir (North)	0.46	269	1076
Southern Pine	0.55	352	1408
Spruce, Pine, Fir	0.42	235	940
Spruce, Pine, Fir (E of 2 million psi and higher grades of MSR and MEL)	0.50	305	1220



- ⁽¹⁾ Each SolarHot hot water collector to be mounted with four (4) mounting feet;
Tilt Mounted collectors to share a common set of (2) mounting feet between panels
- ⁽²⁾ Based on 2-3/8" lag screws per mounting foot embedded 2" in a rafter or other structural roof member
- ⁽³⁾ Pull-out values incorporate a 1.6 safety factor and a 1.6 load duration factor
as recommended by the American Wood Council
- ⁽⁴⁾ See Uniform Building Code for required edge distance
- ⁽⁵⁾ Value for one (1) 3/8" diameter lag screw with one inch (1") of penetration

Conclusion:

Based on the above numbers the worst case scenario (4'x 10' collector mounted in Spruce-Pine-Fir with a specific gravity of 0.42) provides an available pull out value 34% greater than the wind requirements for a 35 psf wind location.

(A)

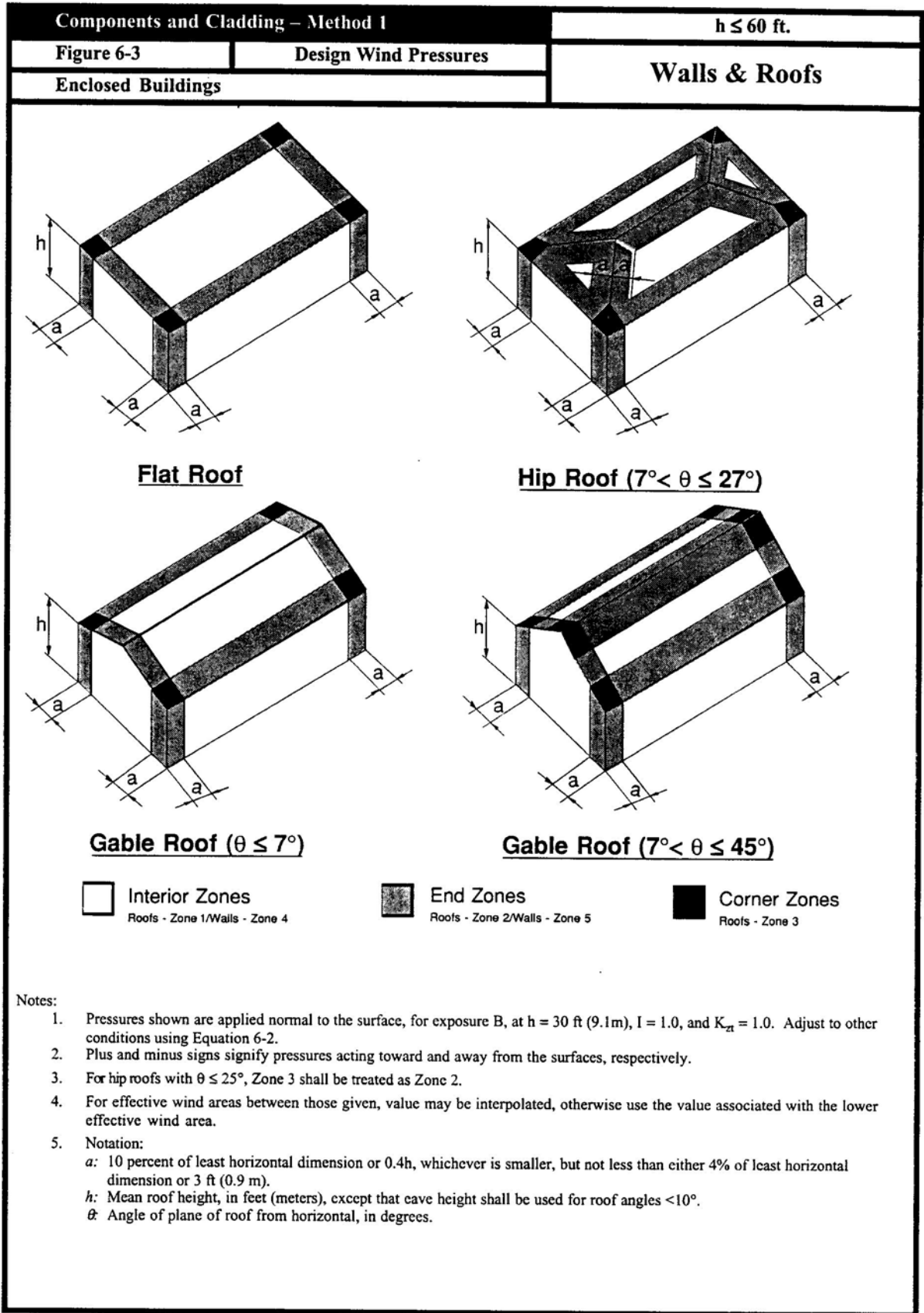



Components and Cladding – Method 1							h ≤ 60 ft.							
Figure 6-3 (cont'd)			Net Design Wind Pressures				Walls & Roofs							
Enclosed Buildings														
Net Design Wind Pressure, p_{net30} (psf) (Exposure B at h = 30 ft. with I = 1.0 and $K_{zt} = 1.0$)														
Zone	Effective wind area (sf)	Basic Wind Speed V (mph)												
		85		90		100		105		110		120		
Roof 0 to 7 degrees	1	10	5.3	-13.0	5.9	-14.6	7.3	-18.0	8.1	-19.8	8.9	-21.8	10.5	-25.9
	1	20	5.0	-12.7	5.6	-14.2	6.9	-17.5	7.6	-19.3	8.3	-21.2	9.9	-25.2
	1	50	4.5	-12.2	5.1	-13.7	6.3	-16.9	6.9	-18.7	7.6	-20.5	9.0	-24.4
	1	100	4.2	-11.9	4.7	-13.3	5.8	-16.5	6.4	-18.2	7.0	-19.9	8.3	-23.7
	2	10	5.3	-21.8	5.9	-24.4	7.3	-30.2	8.1	-33.3	8.9	-36.5	10.5	-43.5
	2	20	5.0	-19.5	5.6	-21.8	6.9	-27.0	7.6	-29.7	8.3	-32.6	9.9	-38.8
	2	50	4.5	-16.4	5.1	-18.4	6.3	-22.7	6.9	-25.1	7.6	-27.5	9.0	-32.7
	2	100	4.2	-14.1	4.7	-15.8	5.8	-19.5	6.4	-21.5	7.0	-23.6	8.3	-28.1
	3	10	5.3	-32.8	5.9	-36.8	7.3	-45.4	8.1	-50.1	8.9	-55.0	10.5	-65.4
	3	20	5.0	-27.2	5.6	-30.5	6.9	-37.6	7.6	-41.5	8.3	-45.5	9.9	-54.2
	3	50	4.5	-19.7	5.1	-22.1	6.3	-27.3	6.9	-30.1	7.6	-33.1	9.0	-39.3
	3	100	4.2	-14.1	4.7	-15.8	5.8	-19.5	6.4	-21.5	7.0	-23.6	8.3	-28.1
Roof > 7 to 27 degrees	1	10	7.5	-11.9	8.4	-13.3	10.4	-16.5	11.4	-18.2	12.5	-19.9	14.9	-23.7
	1	20	6.8	-11.6	7.7	-13.0	9.4	-16.0	10.4	-17.6	11.4	-19.4	13.6	-23.0
	1	50	6.0	-11.1	6.7	-12.5	8.2	-15.4	9.1	-17.0	10.0	-18.6	11.9	-22.2
	1	100	5.3	-10.8	5.9	-12.1	7.3	-14.9	8.1	-16.5	8.9	-18.1	10.5	-21.5
	2	10	7.5	-20.7	8.4	-23.2	10.4	-28.7	11.4	-31.6	12.5	-34.7	14.9	-41.3
	2	20	6.8	-19.0	7.7	-21.4	9.4	-26.4	10.4	-29.1	11.4	-31.9	13.6	-38.0
	2	50	6.0	-16.9	6.7	-18.9	8.2	-23.3	9.1	-25.7	10.0	-28.2	11.9	-33.6
	2	100	5.3	-15.2	5.9	-17.0	7.3	-21.0	8.1	-23.2	8.9	-25.5	10.5	-30.3
	3	10	7.5	-30.6	8.4	-34.3	10.4	-42.4	11.4	-46.7	12.5	-51.3	14.9	-61.0
	3	20	6.8	-28.6	7.7	-32.1	9.4	-39.6	10.4	-43.7	11.4	-47.9	13.6	-57.1
	3	50	6.0	-26.0	6.7	-29.1	8.2	-36.0	9.1	-39.7	10.0	-43.5	11.9	-51.8
	3	100	5.3	-24.0	5.9	-26.9	7.3	-33.2	8.1	-36.6	8.9	-40.2	10.5	-47.9
Roof > 27 to 45 degrees	1	10	11.9	-13.0	13.3	-14.6	16.5	-18.0	18.2	-19.8	19.9	-21.8	23.7	-25.9
	1	20	11.6	-12.3	13.0	-13.8	16.0	-17.1	17.6	-18.8	19.4	-20.7	23.0	-24.6
	1	50	11.1	-11.5	12.5	-12.8	15.4	-15.9	17.0	-17.5	18.6	-19.2	22.2	-22.8
	1	100	10.8	-10.8	12.1	-12.1	14.9	-14.9	16.5	-16.5	18.1	-18.1	21.5	-21.5
	2	10	11.9	-15.2	13.3	-17.0	16.5	-21.0	18.2	-23.2	19.9	-25.5	23.7	-30.3
	2	20	11.6	-14.5	13.0	-16.3	16.0	-20.1	17.6	-22.2	19.4	-24.3	23.0	-29.0
	2	50	11.1	-13.7	12.5	-15.3	15.4	-18.9	17.0	-20.8	18.6	-22.9	22.2	-27.2
	2	100	10.8	-13.0	12.1	-14.6	14.9	-18.0	16.5	-19.8	18.1	-21.8	21.5	-25.9
	3	10	11.9	-15.2	13.3	-17.0	16.5	-21.0	18.2	-23.2	19.9	-25.5	23.7	-30.3
	3	20	11.6	-14.5	13.0	-16.3	16.0	-20.1	17.6	-22.2	19.4	-24.3	23.0	-29.0
	3	50	11.1	-13.7	12.5	-15.3	15.4	-18.9	17.0	-20.8	18.6	-22.9	22.2	-27.2
	3	100	10.8	-13.0	12.1	-14.6	14.9	-18.0	16.5	-19.8	18.1	-21.8	21.5	-25.9
Wall	4	10	13.0	-14.1	14.6	-15.8	18.0	-19.5	19.8	-21.5	21.8	-23.6	25.9	-28.1
	4	20	12.4	-13.5	13.9	-15.1	17.2	-18.7	18.9	-20.6	20.8	-22.6	24.7	-26.9
	4	50	11.6	-12.7	13.0	-14.3	16.1	-17.6	17.8	-19.4	19.5	-21.3	23.2	-25.4
	4	100	11.1	-12.2	12.4	-13.6	15.3	-16.8	16.9	-18.5	18.5	-20.4	22.0	-24.2
	4	500	9.7	-10.8	10.9	-12.1	13.4	-14.9	14.8	-16.5	16.2	-18.1	19.3	-21.5
	5	10	13.0	-17.4	14.6	-19.5	18.0	-24.1	19.8	-26.6	21.8	-29.1	25.9	-34.7
	5	20	12.4	-16.2	13.9	-18.2	17.2	-22.5	18.9	-24.8	20.8	-27.2	24.7	-32.4
	5	50	11.6	-14.7	13.0	-16.5	16.1	-20.3	17.8	-22.4	19.5	-24.6	23.2	-29.3
	5	100	11.1	-13.5	12.4	-15.1	15.3	-18.7	16.9	-20.6	18.5	-22.6	22.0	-26.9
	5	500	9.7	-10.8	10.9	-12.1	13.4	-14.9	14.8	-16.5	16.2	-18.1	19.3	-21.5

Unit Conversions – 1.0 ft = 0.3048 m; 1.0 psf = 0.0479 kN/m²



C

Components and Cladding – Method 1

h ≤ 60 ft.

Figure 6-3 (cont'd) Net Design Wind Pressures

Enclosed Buildings **Walls & Roofs**

Net Design Wind Pressure, p_{net30} (psf) (*Exposure B at h = 30 ft. with I = 1.0 and $K_{zt} = 1.0$*)

	Zone	Effective wind area (sf)	Basic Wind Speed V (mph)											
			125		130		140		145		150		170	
			+	-	+	-	+	-	+	-	+	-	+	-
Roof 0 to 7 degrees	1	10	11.4	-28.1	12.4	-30.4	14.3	-35.3	15.4	-37.8	16.5	-40.5	21.1	-52.0
	1	20	10.7	-27.4	11.6	-29.6	13.4	-34.4	14.4	-36.9	15.4	-39.4	19.8	-50.7
	1	50	9.8	-26.4	10.6	-28.6	12.3	-33.2	13.1	-35.6	14.1	-38.1	18.1	-48.9
	1	100	9.1	-25.7	9.8	-27.8	11.4	-32.3	12.2	-34.6	13.0	-37.0	16.7	-47.6
	2	10	11.4	-47.2	12.4	-51.0	14.3	-59.2	15.4	-63.5	16.5	-67.9	21.1	-87.2
	2	20	10.7	-42.1	11.6	-45.6	13.4	-52.9	14.4	-56.7	15.4	-60.7	19.8	-78.0
	2	50	9.8	-35.5	10.6	-38.4	12.3	-44.5	13.1	-47.8	14.1	-51.1	18.1	-65.7
	2	100	9.1	-30.5	9.8	-33.0	11.4	-38.2	12.2	-41.0	13.0	-43.9	16.7	-56.4
	3	10	11.4	-71.0	12.4	-76.8	14.3	-89.0	15.4	-95.5	16.5	-102.2	21.1	-131.3
	3	20	10.7	-58.5	11.6	-63.6	13.4	-73.8	14.4	-79.1	15.4	-84.7	19.8	-108.7
	3	50	9.8	-42.7	10.6	-46.2	12.3	-53.5	13.1	-57.4	14.1	-61.5	18.1	-78.9
	3	100	9.1	-30.5	9.8	-33.0	11.4	-38.2	12.2	-41.0	13.0	-43.9	16.7	-56.4
Roof > 7 to 27 degrees	1	10	16.2	-25.7	17.5	-27.8	20.3	-32.3	21.8	-34.6	23.3	-37.0	30.0	-47.6
	1	20	14.8	-25.0	16.0	-27.0	18.5	-31.4	19.9	-33.7	21.3	-36.0	27.3	-46.3
	1	50	12.9	-24.1	13.9	-26.0	16.1	-30.2	17.3	-32.4	18.5	-34.6	23.8	-44.5
	1	100	11.4	-23.2	12.4	-25.2	14.3	-29.3	15.4	-31.4	16.5	-33.6	21.1	-43.2
	2	10	16.2	-44.8	17.5	-48.4	20.3	-56.2	21.8	-60.3	23.3	-64.5	30.0	-82.8
	2	20	14.8	-41.2	16.0	-44.6	18.5	-51.7	19.9	-55.4	21.3	-59.3	27.3	-76.2
	2	50	12.9	-36.5	13.9	-39.4	16.1	-45.7	17.3	-49.1	18.5	-52.5	23.8	-67.4
	2	100	11.4	-32.9	12.4	-35.6	14.3	-41.2	15.4	-44.2	16.5	-47.3	21.1	-60.8
	3	10	16.2	-66.2	17.5	-71.6	20.3	-83.1	21.8	-89.1	23.3	-95.4	30.0	-122.5
	3	20	14.8	-61.9	16.0	-67.0	18.5	-77.7	19.9	-83.3	21.3	-89.2	27.3	-114.5
	3	50	12.9	-56.2	13.9	-60.8	16.1	-70.5	17.3	-75.7	18.5	-81.0	23.8	-104.0
	3	100	11.4	-51.9	12.4	-56.2	14.3	-65.1	15.4	-69.9	16.5	-74.8	21.1	-96.0
Roof > 27 to 45 degrees	1	10	25.7	-28.1	27.8	-30.4	32.3	-35.3	34.6	-37.8	37.0	-40.5	47.6	-52.0
	1	20	25.0	-26.7	27.0	-28.9	31.4	-33.5	33.7	-35.9	36.0	-38.4	46.3	-49.3
	1	50	24.1	-24.8	26.0	-26.8	30.2	-31.1	32.4	-33.3	34.6	-35.7	44.5	-45.8
	1	100	23.3	-23.3	25.2	-25.2	29.3	-29.3	31.4	-31.4	33.6	-33.6	43.2	-43.2
	2	10	25.7	-32.9	27.8	-35.6	32.3	-41.2	34.6	-44.2	37.0	-47.3	47.6	-60.8
	2	20	25.0	-31.4	27.0	-34.0	31.4	-39.4	33.7	-42.3	36.0	-45.3	46.3	-58.1
	2	50	24.1	-29.5	26.0	-32.0	30.2	-37.1	32.4	-39.8	34.6	-42.5	44.5	-54.6
	2	100	23.2	-28.1	25.2	-30.4	29.3	-35.3	31.4	-37.8	33.6	-40.5	43.2	-52.0
	3	10	25.7	-32.9	27.8	-35.6	32.3	-41.2	34.6	-44.2	37.0	-47.3	47.6	-60.8
	3	20	25.0	-31.4	27.0	-34.0	31.4	-39.4	33.7	-42.3	36.0	-45.3	46.3	-58.1
	3	50	24.1	-29.5	26.0	-32.0	30.2	-37.1	32.4	-39.8	34.6	-42.5	44.5	-54.6
	3	100	23.3	-28.1	25.2	-30.4	29.3	-35.3	31.4	-37.8	33.6	-40.5	43.2	-52.0
Wall	4	10	28.1	-30.5	30.4	-33.0	35.3	-38.2	37.8	-41.0	40.5	-43.9	52.0	-56.4
	4	20	26.8	-29.2	29.0	-31.6	33.7	-36.7	36.1	-39.3	38.7	-42.1	49.6	-54.1
	4	50	25.2	-27.5	27.2	-29.8	31.6	-34.6	33.9	-37.1	36.2	-39.7	46.6	-51.0
	4	100	23.9	-26.3	25.9	-28.4	30.0	-33.0	32.2	-35.4	34.4	-37.8	44.2	-48.6
	4	500	21.0	-23.3	22.7	-25.2	26.3	-29.3	28.2	-31.4	30.2	-33.6	38.8	-43.2
	5	10	28.1	-37.6	30.4	-40.7	35.3	-47.2	37.8	-50.6	40.5	-54.2	52.0	-69.6
	5	20	26.8	-35.1	29.0	-38.0	33.7	-44.0	36.1	-47.2	38.7	-50.5	49.6	-64.9
	5	50	25.2	-31.8	27.2	-34.3	31.6	-39.8	33.9	-42.7	36.2	-45.7	46.6	-58.7
	5	100	23.9	-29.2	25.9	-31.6	30.0	-36.7	32.2	-39.3	34.4	-42.1	44.2	-54.1
	5	500	21.0	-23.2	22.7	-25.2	26.3	-29.3	28.2	-31.1	30.2	-33.6	38.8	-43.2

Unit Conversions – 1.0 ft = 0.3048 m; 1.0 psf = 0.0479 kN/m²

(D)

Components and Cladding – Method 1		h ≤ 60 ft.
Figure 6-3 (cont'd)	Net Design Wind Pressures	
Enclosed Buildings		Walls & Roofs

Roof Overhang Net Design Wind Pressure, p_{net30} (psf)
(Exposure B at h = 30 ft. with I = 1.0)

	Zone	Effective Wind Area (sf)	Basic Wind Speed V (mph)							
			90	100	110	120	130	140	150	170
Roof 0 to 7 degrees	2	10	-21.0	-25.9	-31.4	-37.3	-43.8	-50.8	-58.3	-74.4
	2	20	-20.6	-25.5	-30.8	-36.7	-43.0	-49.9	-57.3	-73.6
	2	50	-20.1	-24.9	-30.1	-35.8	-42.0	-48.7	-55.5	-71.8
	2	100	-19.8	-24.4	-29.5	-35.1	-41.2	-47.8	-54.9	-70.5
Roof > 7 to 27 degrees	3	10	-34.6	-42.7	-51.6	-61.5	-72.1	-83.7	-96.0	-123.4
	3	20	-27.1	-33.5	-40.5	-48.3	-56.6	-65.7	-75.4	-96.8
	3	50	-27.3	-33.5	-40.5	-48.3	-56.6	-65.7	-75.4	-96.8
	3	100	-10.0	-12.2	-14.8	-17.6	-20.6	-23.9	-27.4	-35.2
Roof > 27 to 45 degrees	2	10	-27.2	-33.5	-40.6	-48.3	-56.7	-65.7	-75.5	-96.9
	2	20	-27.2	-33.5	-40.6	-48.3	-56.7	-65.7	-75.5	-96.9
	2	50	-27.2	-33.5	-40.6	-48.3	-56.7	-65.7	-75.5	-96.9
	2	100	-27.2	-33.5	-40.6	-48.3	-56.7	-65.7	-75.5	-96.9
	3	10	-45.7	-56.4	-68.3	-81.9	-95.3	-110.6	-126.9	-163.0
	3	20	-37.2	-50.9	-61.6	-73.3	-86.0	-99.8	-114.5	-147.1
	3	50	-35.3	-43.6	-52.8	-62.8	-73.5	-85.5	-98.1	-126.1
	3	100	-30.9	-38.1	-46.1	-54.9	-64.4	-74.7	-85.8	-110.1

Adjustment Factor for Building Height and Exposure, λ

Mean roof height (ft)	Exposure		
	B	C	D
15	1.00	1.21	1.47
20	1.00	1.29	1.55
25	1.00	1.35	1.61
30	1.00	1.40	1.66
35	1.05	1.45	1.70
40	1.09	1.49	1.74
45	1.12	1.53	1.78
50	1.16	1.56	1.81
55	1.19	1.59	1.84
60	1.22	1.62	1.87

Unit Conversions – 1.0 ft = 0.3048 m; 1.0 sf = 0.0929 m²; 1.0 psf = 0.0479 kN/m